

# Universal Loader K2 P



## Technical Data

Engine, <b>Euro Stage III</b> :	Kubota, 4-cyl. diesel engine, water cooled, 25 kW (34 HP)
Engine, <b>Euro Stage V</b> :	Kubota, 4-cyl. gasoline engine, water cooled, 43 kW (58 HP)
Lifting capacity:	1200 kg standard, 1600 kg with lifting cylinders Ø 115mm and counter weights (max. 300 kg)
Lifting height:	3300 mm, lower side pallet fork
Tipping load:	1300 kg, straight in-line, telescope retracted
Front axle:	Stiff, optionally telescopic, width 1207-1837 mm
Rear axle:	Pendulous rear axle
Front loader:	Hydraulic telescopic lift mast, max. height 3.3 m
Drive:	All-wheel, hydrostatic drive at each wheel, 0-18 km/h
Driving hydraulic:	Adjustable axial piston pump, 116 l/min, 400 bars, 4 fully hydraulic wheel motors
Working hydraulics:	Gear type pump, 47 l/min, 180 bars
Service brake:	By hydrostatic drive, on all wheels
Parking brake:	Spring loaded brake inside front wheels motors
Tyres:	Standard 10.0/75 – 15.3AS, tot. loader width 1.207-1.837 m Optionally 31 x 15.50-15 tot. loader width 1.40 - 2.03 m
Driver seat:	Comfort seat, safety belt, integrated contact switch
Steering column:	Comfort steering column, inclination adjustable, operating hours counter, fuel gauge
Tool carrier:	EURO-Norm with mech. locking (standard)
Diesel / oil tank	Integrated safety tanks, 20 l / 40 l
Empty weight:	2060 kg (front / rear axle 590 / 1470 kg)
Turn. radius outside:	2180 mm, articulating angle 55°

Data for information only, modifications reserved



# Universal Loader K2 P

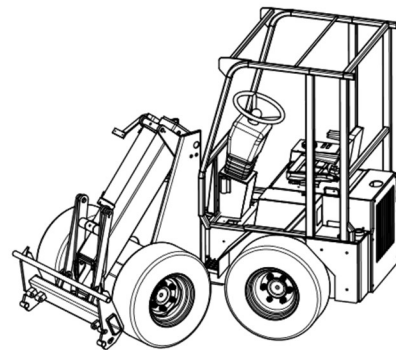
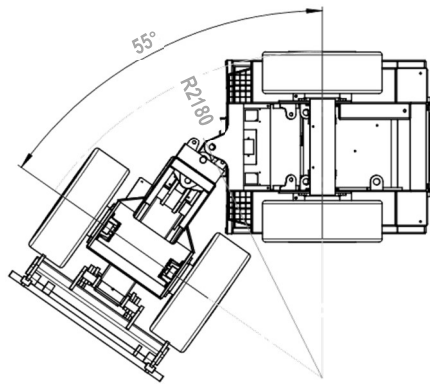
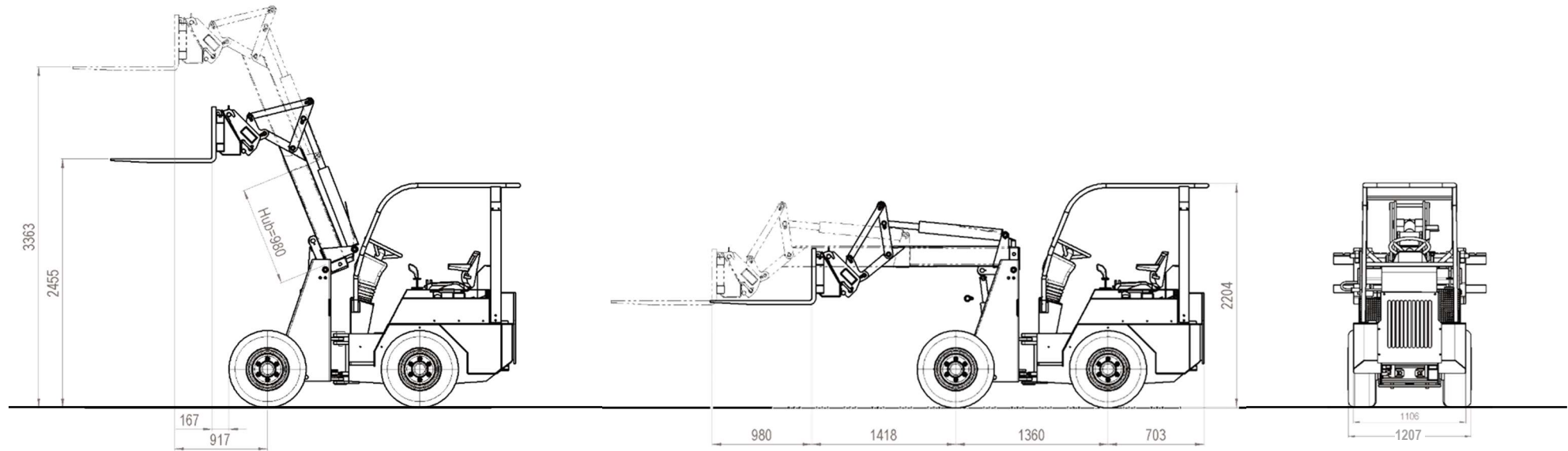

- Short wheelbase of only 1.35 m
- Narrow chassis of only 1.10 m width
- Low height of only 2.20 m
- Tight turning radius outside of only 2.18 m
- High lifting height up to 3.30 m
- High lifting capacity up to 1.6 t
- **Optimal composition of compactness, manoeuvrability, large workspace and high lifting capacity**

Data for information only, modifications reserved