

Universal Loader

K2S

*the strong with
oscillator*



Eigene Entwicklung und
Fertigung nach CE-Norm



Schlingenerstraße 2a ▪ D-87668 Rieden ▪ Tel.: +49 8346 982026
E-Mail: info@ostler-maschinenbau.de ▪ www.ostler-maschinenbau.de

Data Sheet

Weights		
Unladen weight		2060 kg
	Front section	590 kg
	Rear section	1470 kg
Drive		
Engine	4 cylinder Kubota engine, diesel, water-cooled	18,5kW/25HP at 2300 rpm
	or 4 cylinder Kubota engine, petrol, water-cooled	43kW/58HP at 3600 rpm
Fueltank		Tank capacity 20l
Traction hydraulics	Adjustable axial piston pump	4 fully hydrostatic wheel motors in direct drive
Drive	continuously variable hydrostatic all-wheel drive	0–18 km/h
Rear axle	oscillating	
Tyres	Standard 10.0/75-15.3-AS	(Width of machine 1.24 m)
	Optional 31x15,50-15	(Width of machine 1.40 m)
Performance (lateral counterweights standard since 2011)		
Tipping load loader -straight and Telescope retracted		1300 kg (with counterweight)
Lifting capacity		1200 kg
Lifting height (lower edge pallet bracket)		3060 mm
Brakes		
Service brake		via hydrostatic drive, acting on front and rear axle
Parking brake		acting on rear axle
Steering		
Type of steering		articulated steering with 2 steering cylinders
Steering column		comfort steering column (vertically adjustable) with working hour meter, fuel gauge and rpm counter
Seat		
		comfort seat with safety belt (with integrated contact switch)
Hydraulic system		
Hydraulic system	180 bar	Diesel 36 l/min Petrol 58 l/min
Flow rate for drive		133.4 l/min
System pressure for drive		400 bar
Contents of hydraulic tank		40l
Tool installation		
EURO standard attachment with mechanical locking (standard equipment)		
Turning radius (with standard tyres)		
On inner edge		1180 mm
On outer edge		2180 mm

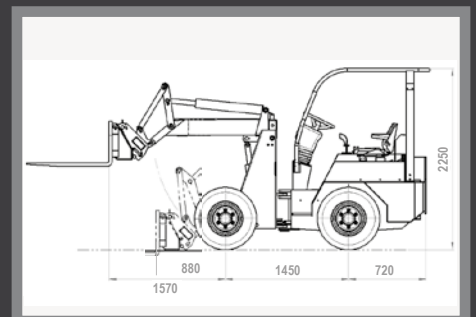
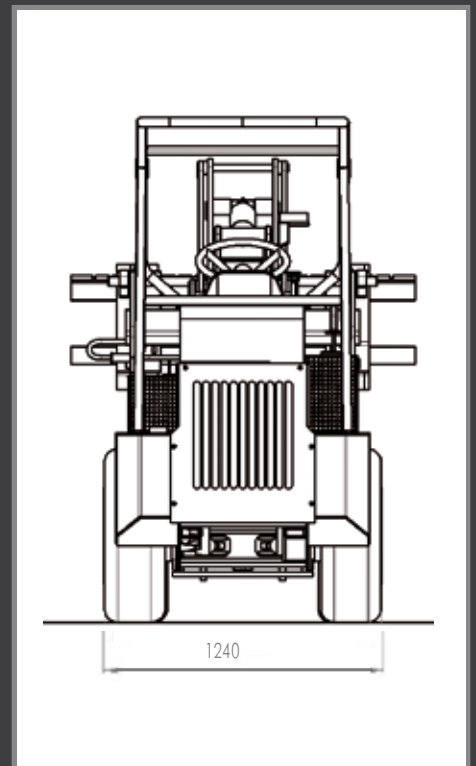
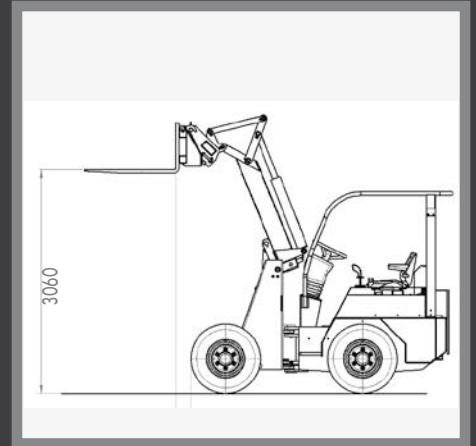

Dimensions are not binding;
Changes in design may be subject to alterations.