

Universal Loader K4



Technical Data

Engine, Euro Stage V :	Kubota gasoline engine, 4-cyl., water cooled 65 kW (88 HP)
Lifting capacity:	2000 kg
Lifting height:	4692 mm, lower side of pallet fork
Tipping load:	1920 kg, straight in-line, telescope retracted
Front axle:	Telescopic front axle, width 1728 – 2481 mm
Rear axle:	Standardly stiff, optionally pendulous
Front loader:	Hydraulic telescopic lift mast, max. height 4.55 m
Drive:	All-wheel, hydrostatic drive at each wheel, 0-25 km/h
Driving hydraulic:	Adjustable axial piston pump, 250 l/min, 400 bars, 4 fully hydraulic wheel motors, direct drive
Working hydraulics:	Gear type pump, 78 l/min, 180 bars
Service brake:	By hydrostatic drive, on all wheels
Parking brake:	Spring loaded brake inside front wheels motors
Tyres:	Standard 15.0/55 - 17AS, total width 1,73 - 2,48 m
Driver seat:	Comfort seat, safety belt, integrated contact switch
Steering column:	Comfort steering column, inclination adjustable, operating hours counter, fuel gauge
Tool carrier:	EURO-Norm with mech. Locking (standard)
Counter weights:	max. 300 kg
Diesel- / oil tank	Integrated safety tanks, 130 l / 130 l
Empty weight:	4740 kg (front- / rear axle 1530 / 3210 kg)
Turning radius:	Inside 1085 mm, outside 2850 mm, articulating angle 55°

Data for information only, modifications reserved



Universal Loader K4

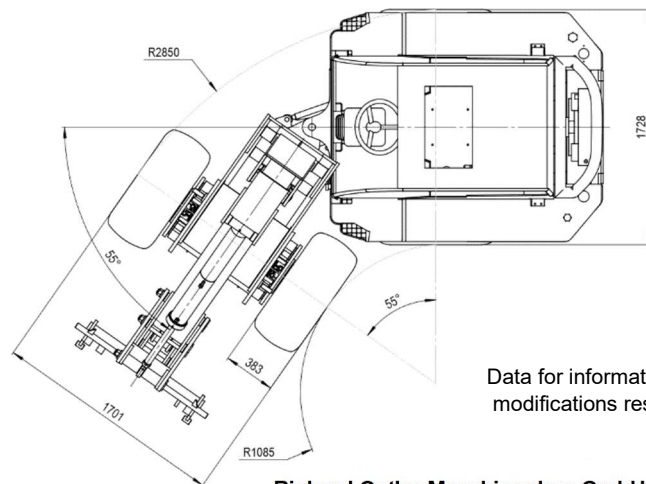
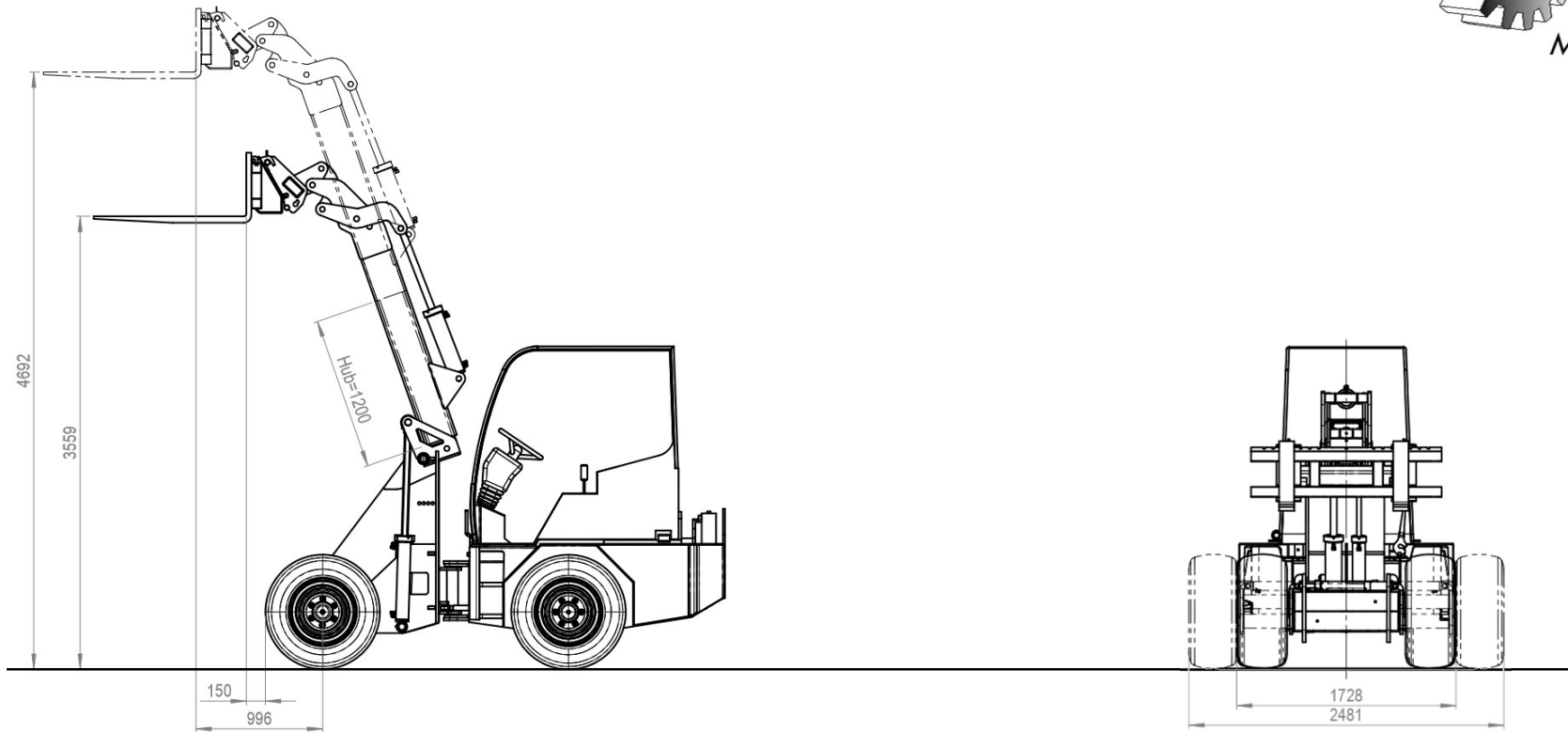

Data for information only,
modifications reserved

